



Informal Settlement Solid Waste Management Optimization in eThekweni Municipality

February 2022



“iQhaza Lethu”

An informal settlement upgrading partnership initiative co-funded by the European Union



Informal Settlements in eThekweni

- Over 587 urban informal settlements, 312,741 households.
- Nearly a quarter of the City's population.
- Continued urbanization and scarcity of well-located land.
- Over 80 years to address the informal settlement backlog by means of conventional housing delivery.
- **Incremental, in-situ upgrading of informal settlements is national policy as per the UISP.**
- Challenging topography, high densities and many settlements within environmentally sensitive areas
- **78% of settlements are category B1 (incremental in-situ upgrade with essential services) - 352 settlements, 246,348 hh.**
- Many are very dense (200+ du per hectare)
- Less than 3% of households earmarked for relocation (due mainly to sites being unsafe for habitation).
- **Solid waste is a critical essential service and receives a high priority in the draft City-wide Incremental Upgrading Strategy.**



Severe solid waste accumulation is a major problem in informal settlements, posing environmental, pollution, public health and storm-water problems



Settlement Overview eThekweni – The scale of the challenge

The scale of informal settlements in the Municipality is a key factor informing the Strategy. This has significant strategic implications including the impossibility of addressing the ‘backlogs’ by means of formal housing provision or comprehensive upgrading and the necessity for an optimized incremental approach.

Summary of settlements by NUSP category

NUSP Categorisation	No. settlements	Est. households	% Settlements	% households
A (full conventional upgrading i.e. housing project)	56	22 131	9,5%	7,1%
B1 (Incremental upgrade with essential services)**	352	246 348	60,0%	78,8%
B2 (Deferred relocation with emergency services)	135,5	33 009	23,1%	10,6%
C (Imminent relocation)	34,5	10 954	5,9%	3,5%
Under investigation	9	299	1,5%	0,1%
	587	312 741	100,0%	100,0%

*** 35% of B1s are best located (inside PIC and urban zone) - 202 settlements, 97,113hh, 35% of all settlements, 31% of all hh. Note household numbers as at July 2021 at time of pipeline analysis – there has been a slight increase subsequently.*

Nature of Refuse Removal: All Settlements

iQhaza Lethu Socio Survey 10 pilots:

- 49% municipal collection point
- 28% informal dump site
- 12% dump near house
- 5% burn rubbish
- 1% throw in river

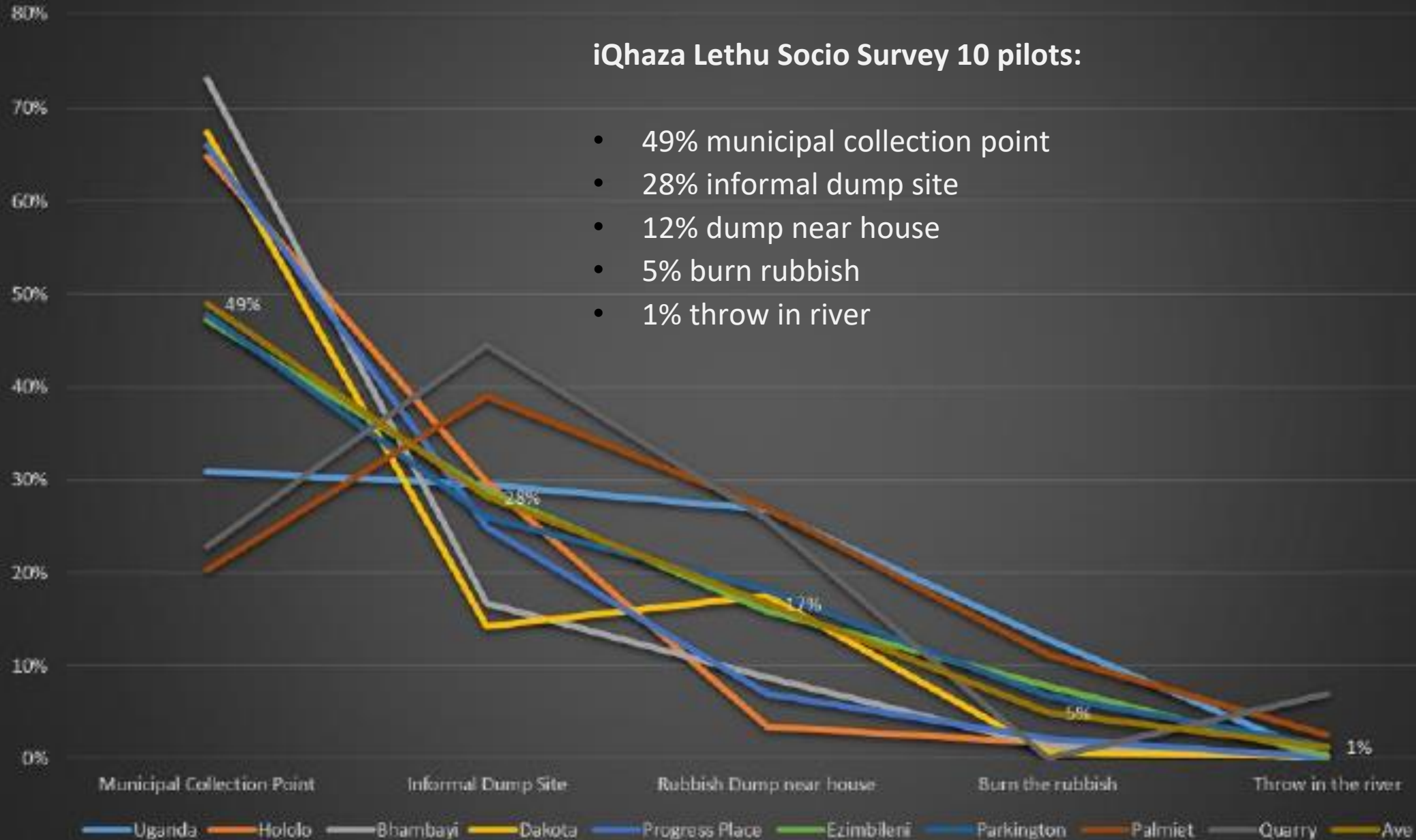

Optimised solid waste approach for informal settlements

Status quo: Solid waste is collected weekly from collection points at the edge of each settlement but there is no solution in place for moving waste from inside the settlement to the collection point. As a result, most solid waste is not removed from the settlement and accumulates in large volumes in informal waste dumps, streams and vegetated areas. Weekly collection is not always regular and waste at collection points is not contained. This results in environmental pollution including of streams and rivers, public health risks both to informal residents and neighboring formal communities, harm to tourism through polluted beaches, and damage to municipal storm-water controls.

Optimized approach: Solid waste bins are installed inside the settlement with solid waste collectors moving the waste twice a week to the main collection point. An adequate containment area is established at the collection point (fenced with a slab and drainage to collect any leachate). This approach can go hand-in-hand with a 'services frame' for best-located category B1 settlements (i.e. a services network within the settlement along main alignments with footpaths, storm-water controls, mini communal ablutions, fire hydrants etc.). There is the potential to separate and process recyclable waste, although this needs to form part of a broader solution in the city for recycling. This would also reduce the pressure on municipal land-fills and enable an additional revenue stream in the long run making solid waste management more sustainable. A key success factor is to pilot different models for more cost-effective, locally-accountable collection solutions (to remove waste from within settlements), which reduce the O&M burden on the Municipality e.g. such as NGO/CSO partnerships and social enterprise models.

Motivating factors : a) Reduced health and safety risks to residents; b) Cost savings on infrastructure damage e.g. storm-water blockage and damage; c) Environmental harm reduction e.g. stream and beachfront pollution; d) Improved relationships with neighboring rate-payers & reduced complaints regarding smell and visual impacts.

Optimised solid waste model for informal settlements

(note – this is a preliminary model with piloting and further assessment required)

- **Improved SW containment and collection** point accessible to municipal SW collection trucks / contractors who collect at least weekly (mesh fenced, concrete slab, leachate gully / drain)
- **Solid waste bins inside the settlement** accessible to residents (metal bin, suspended, with concrete slab, leachate gully/drain). One per 60 households. Emptied twice weekly.
- **Municipality provides black bags** to households at least a bag a week (potentially at some point different color bags to facilitate waste separation at source and recycling)
- **Residents are responsible for bagging their waste** and putting it in the bins.
- **Local solid waste collectors** service 200 households each (i.e. carry bags from bins to collection point twice weekly to prevent bins from over-filling and also collect a certain amount of waste left in public space) – two days a week required to achieve this.
- **Potential to link this to solid waste streaming and recycling** of certain waste e.g. plastic and glass via Green Corridors e.g. Ocean Pavers; Green Pavers. Possibly add Johanna Rd to build Green Corridor link and test viability.
- **Cost structure for optimized solid waste collection model (annual):** Annual cost per household of approx. R130 - for a typical settlement of 600hh = R78,000. This includes costs of workers, supervisors and all overheads (management, equipment, clothing, bags etc.) but excludes: a) capital costs for installing solid waste bins inside the settlement and containment facilities at collection points; b) municipal collection from settlements (at least weekly); c) possible revenue from sale of recyclable waste should a solution be found.

Progress and current initiatives

- **City-wide Incremental upgrading Strategy (2021/22)** : Which prioritizes solid waste as a critical health and safety intervention for all informal settlements in the Municipality. The Strategy has been supported by the City's Executive Management Committee in January 2022 and will be tabled to Council soon for adoption, having been developed through extensive engagement with all key municipal line departments and having been supported by the Informal Settlement Incremental Upgrading Forum (ISIUF). The development of the optimized Strategy was mandated by Council in 2019.
- **Solid Waste Working Group (2021/22)**: A multi-departmental working team addressing solid waste solutions for informal settlements has been established (including eThekweni Cleansing and Solid Waste and Human Settlements). It has been agreed by the WG that the optimized model should be provided to Council in the form of a report with recommendations for budget allocation for piloting the rollout of the optimized approach.
- **PEP pilot (March-August 2022)**: Solid waste collection and fire protection for 12 pilot settlements, 9,000 households at a total cost of R2.9m with 95 workers including solid waste collectors, fire marshals, supervisors (CDCs), overheads (equipment, management, bags etc. at 30% of total costs). Project and funding already approved. PEP= Public Employment Programme of National Treasury).
- **Other pilot projects and partnerships (2015-22)**: The optimized approach has been informed by various pilot projects, initiatives and partnerships with various local support organizations. E.g. iQhaza Lethu Incremental Upgrading Partnership Initiative, Project Preparation Trust (PPT), University of KwaZulu Natal, Green Corridor, Shack Dwellers International (SDI), eThekweni Conservancies Forum etc.

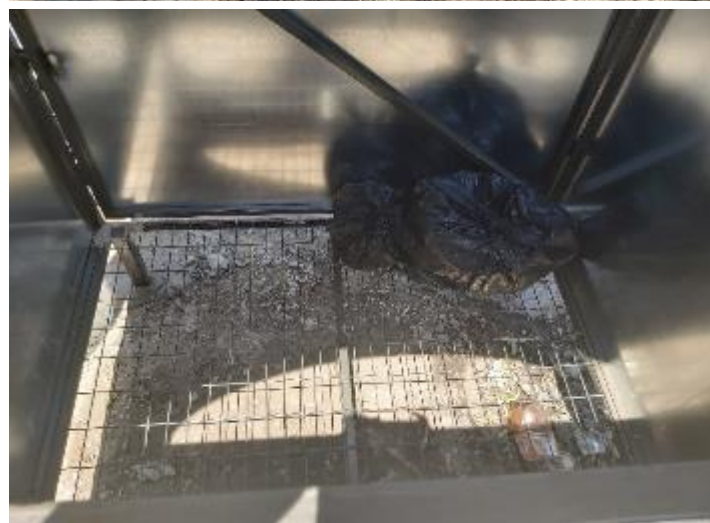

**Solid waste bins inside
the settlement
(Quarry Rd test bins):**

Cost approx. R12,500 incl. labour

**Drain for leachate to be added on future
bins**

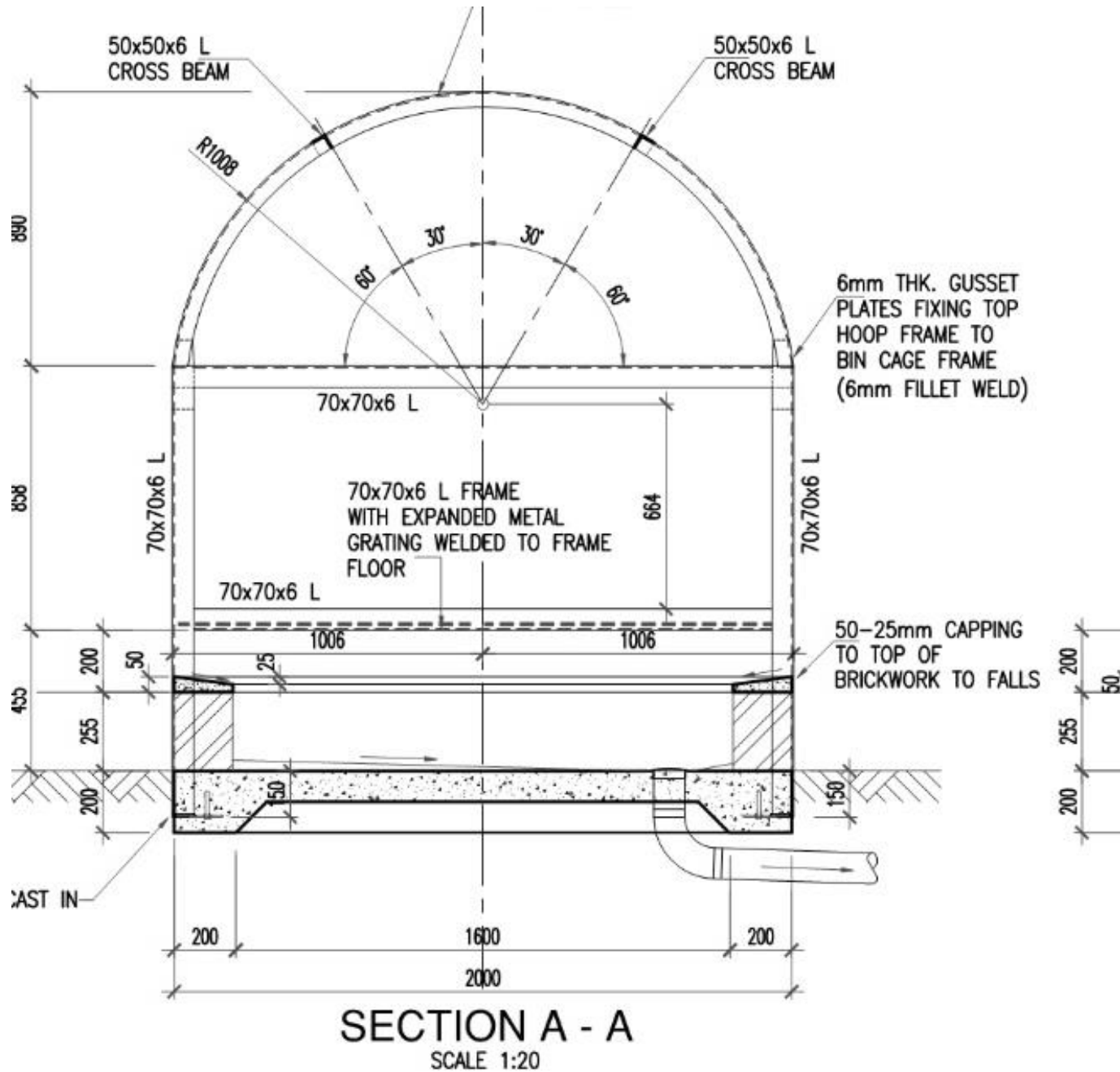

Design for solid waste bins –

1 per 60 households, emptied twice weekly:

Cost approx. R12,500 including materials and labour

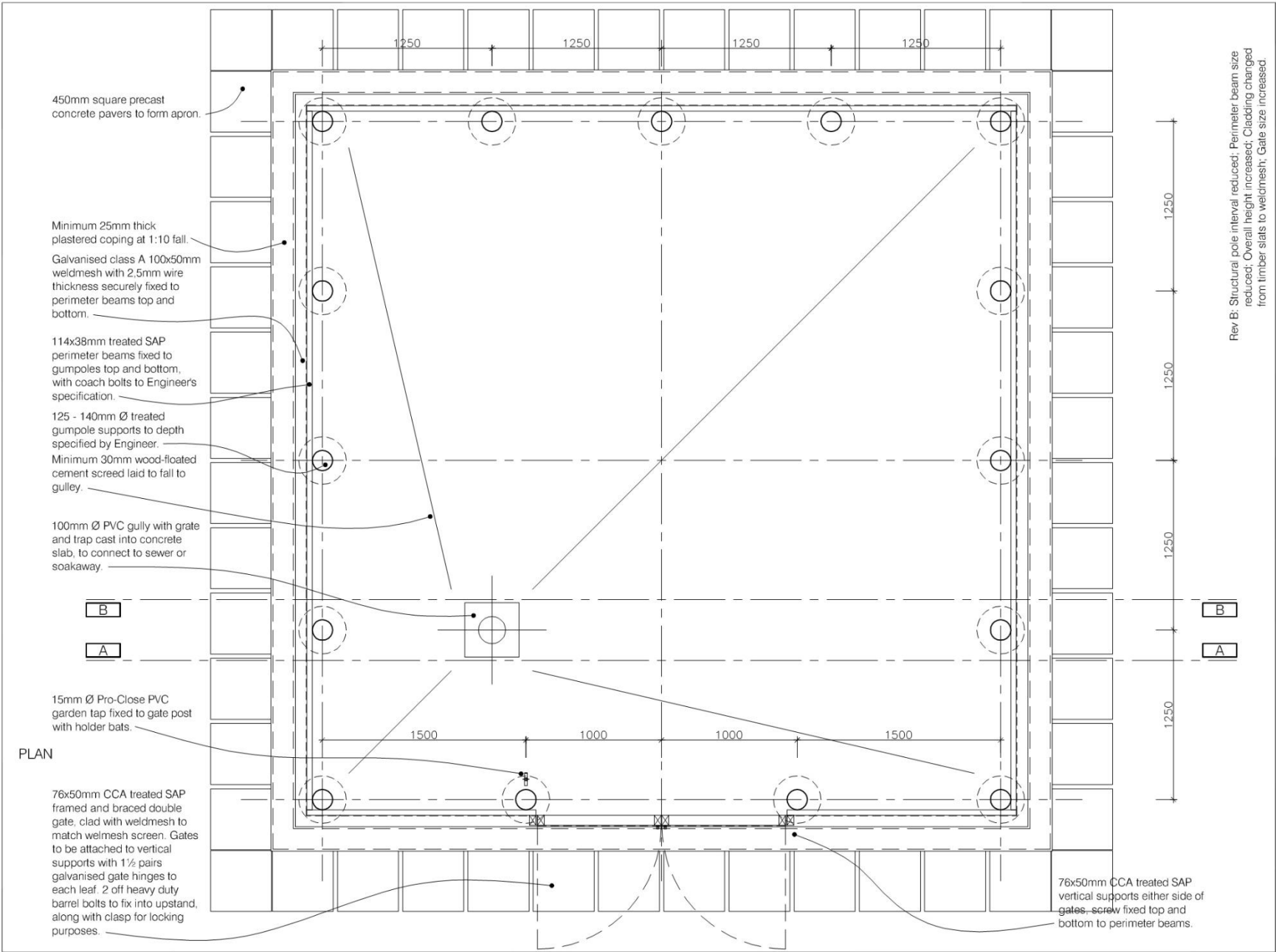

Project Description:		Revision Date		Scale		Page	
IQhaza Lethu: Alternative Dwelling Unit Typologies: TYPE J - 25m ² Waste Collection Yard		MAR '21		DCL		1 of 3	
		JOB No. P19004		WD		Revision B	
		Discipline AR		j101		Draw No.	
DesigncoLab architects + urbanists							

Solid Waste containment & collection area:

Usually 1 per settlement, emptied once weekly.

5mx5mx2mhigh, mesh fence (galvanised welded), treated poles, gate entrance, concrete slab with drain for leachate.

Cost approx. R46,000 including materials and labour

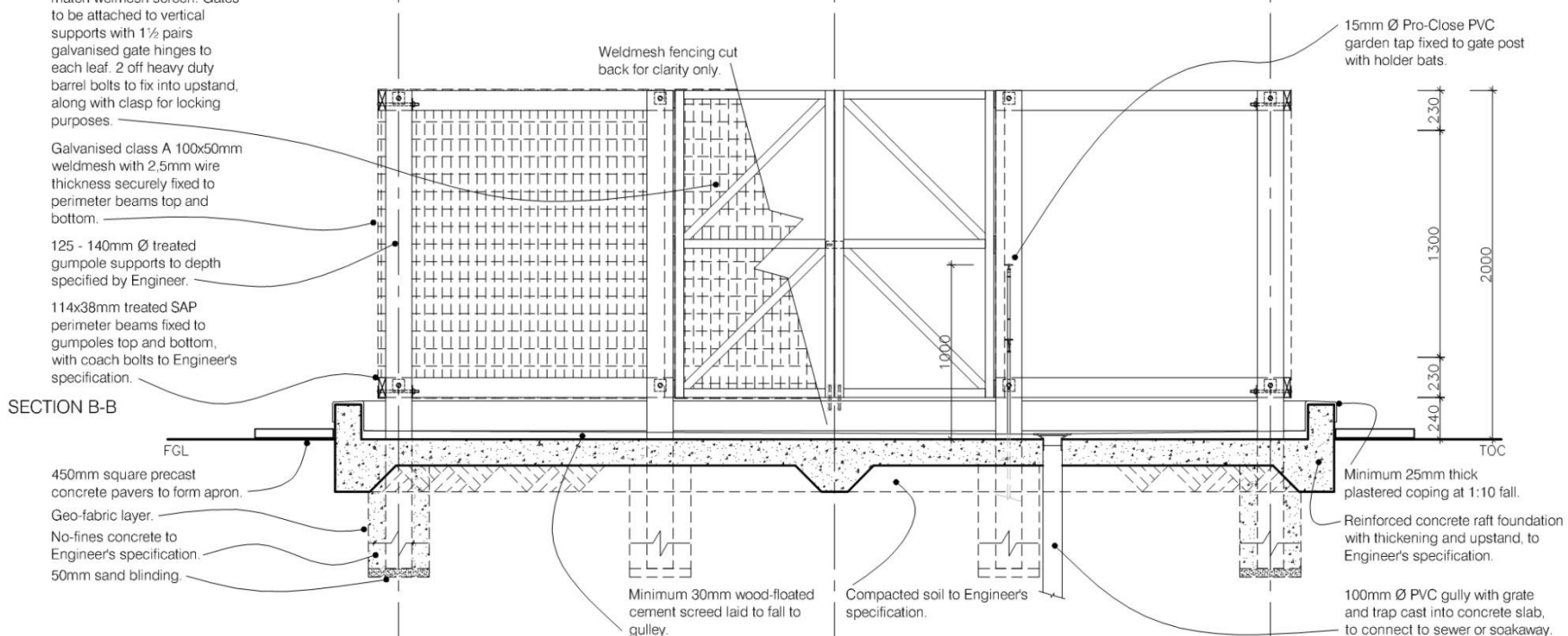
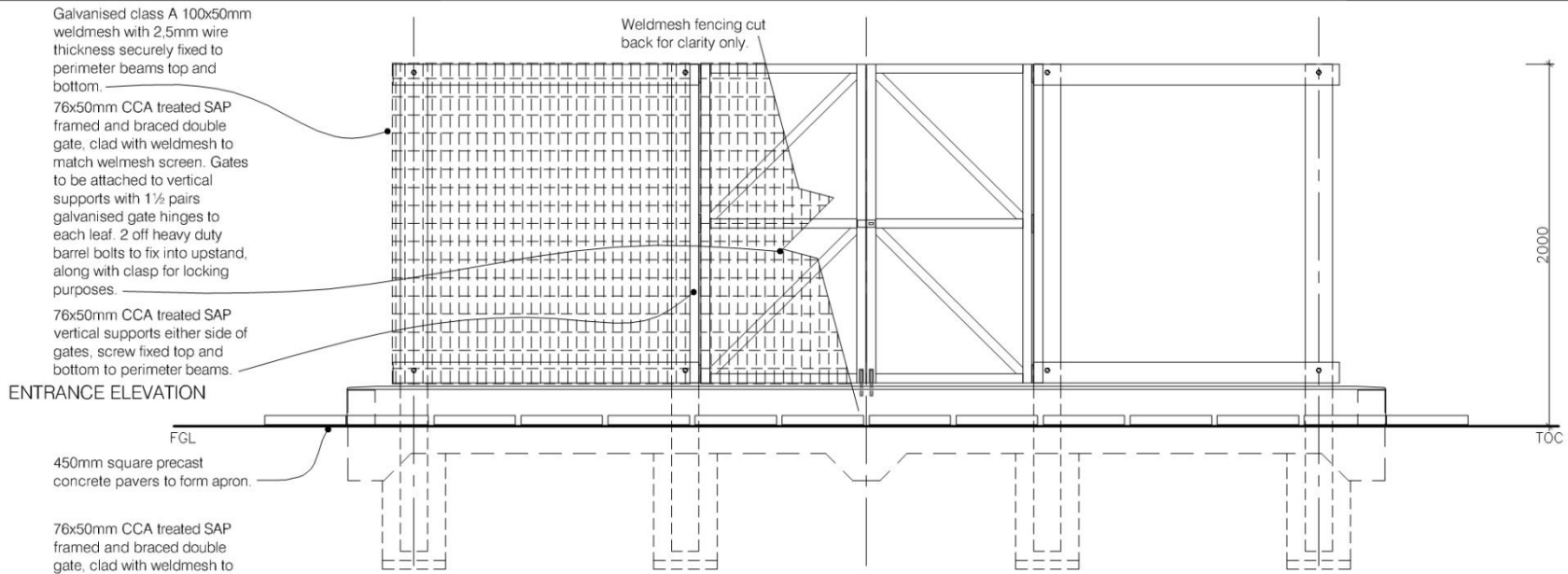

Rev B: Structural pole interval reduced; Perimeter beam size reduced; Overall height increased; Cladding changed from timber slats to weldmesh; Gate size increased.

Revision Date	MAR '21	Revision No.	P19004
Date	AUG '20	Discipline	AR
Drawn	DCL	Stage	WD
Scale	1:25	Dwg No.	j103
Page:	3 of 3	Revision	B

Project Description:
 IQhaza Lethu:
 Alternative Dwelling Unit Typologies:
 TYPE J - 25m² Waste Collection Yard

DesigncoLab
 architects + urbanists

**Solid Waste
 containment
 & collection
 area:**

**(elevation
 view)**



eZimbileni

Informal Settlement
eThekweni Municipality, Ward 22,
Incremental Services
Upgrading Concept Plan

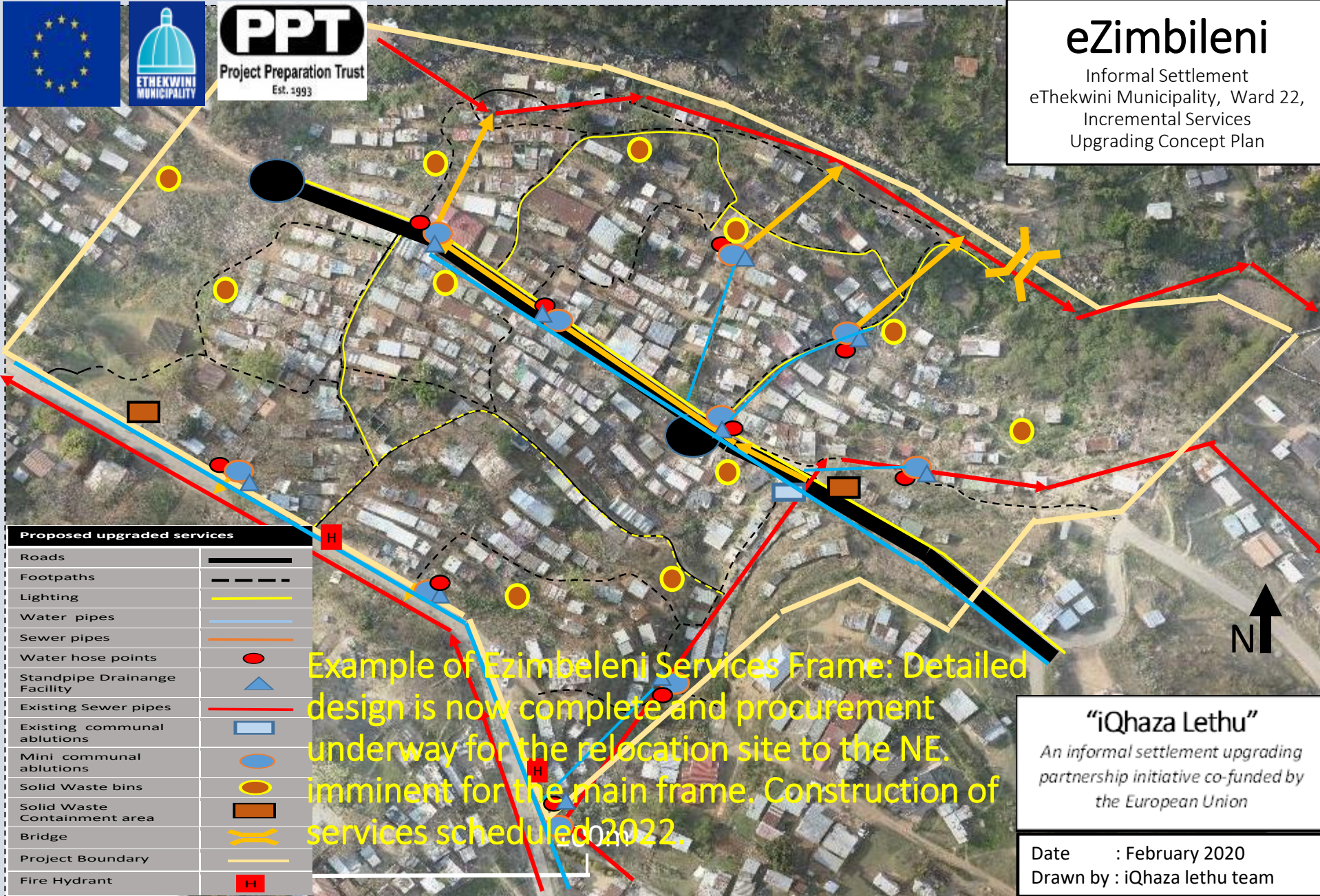

Proposed upgraded services	
Roads	
Footpaths	
Lighting	
Water pipes	
Sewer pipes	
Water hose points	
Standpipe Drainage Facility	
Existing Sewer pipes	
Existing communal ablutions	
Mini communal ablutions	
Solid Waste bins	
Solid Waste Containment area	
Bridge	
Project Boundary	
Fire Hydrant	

Example of Ezimbeleni Services Frame: Detailed design is now complete and procurement underway for the relocation site to the NE, imminent for the main frame. Construction of services scheduled 2022.

"iQhaza Lethu"
An informal settlement upgrading partnership initiative co-funded by the European Union

Date : February 2020
Drawn by : iQhaza lethu team

Parkington,

informal settlement, eThekweni
municipality, Ward 34,
Incremental Upgrading Service
Upgrading **Concept Plan**



“iQhaza Lethu”

*An informal settlement upgrading
partnership initiative co-funded by
the European Union*

Proposed upgraded services

Roads	
Footpaths	
Lighting	
Water pipes	
Sewer pipes	
Water hose points	
Standpipe Drainage Facility	
Existing Sewer pipes	
Existing communal ablutions	
Mini communal ablutions	
Solid Waste bins	
Solid Waste Containment area	
Bridge	
Project Boundary	
Fire Hydrant	

Example of Parkington Services Frame Concept –
Detailed design is now complete and
procurement underway for the relocation site to
the NE. imminent for the main frame.
Construction of services scheduled 2022.

Date : February 2020
Drawn by : iQhaza lethu - team

100 m

